

# Early Mathematics - Egypt and Mesopotamia

Fall 2025 - R. L. Herman

---



# Maps of Ancient Civilizations

## Ancient Civilizations of the Old World

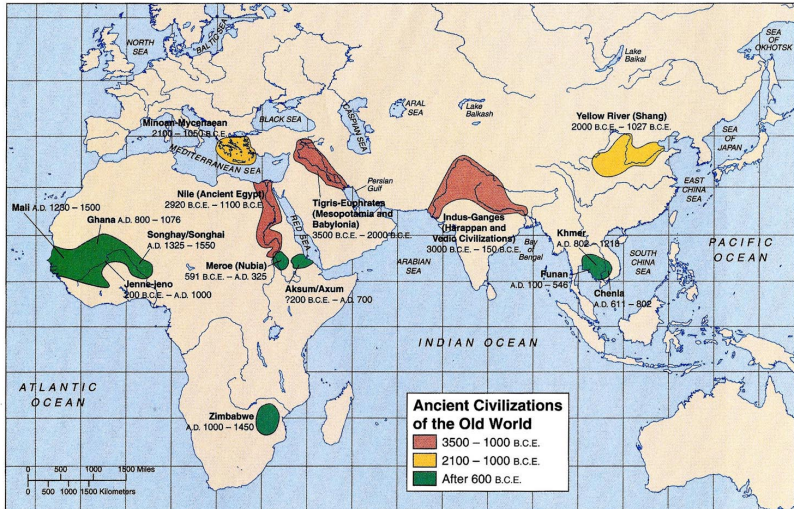

# Early Civilizations

- Ancient African  $\approx$  20,000 yrs
- Egypt (3150-30 BCE)
- Mesopotamia (3100-539 BCE)
- Indus (3300-1700 BCE)
- Greek (640 BCE-415 CE)
- Chinese (1766 BCE-220 CE)
- Indian Mathematics (500-1200)
- Islamic Mathematics (700-1200)
- Mayan Mathematics (250-900)
- Aztec Empire (c.1345-1521)
- Inca Civilization (1400-1560)

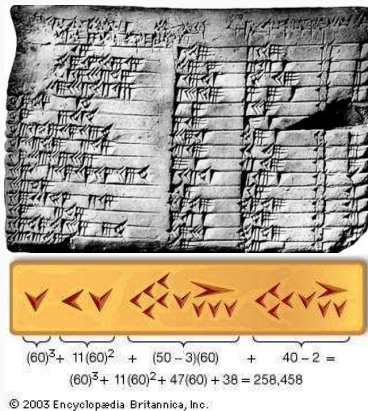

**Figure 1:** Babylonian tablet - Base 60

# Ancient African Mathematics

- Lebombo bone, 43,000-44,200 yrs old. Oldest known mathematical artifact, 29 notches on a baboon's fibula. Found in Border Cave, Lebombo Mountains, Swaziland.
- Ishango bone, 20,000 BCE. Also baboon bone. Ishango, Democratic Republic of Congo. Numerical patterns with differing interpretations.



[See Blog and Article](#)

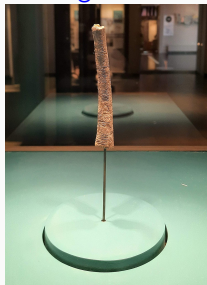

[See Wikipedia.](#)

# Ancient Egypt

- Early Dynastic Period (3150–2686 BCE), writing
- Old Kingdom (2686–2181 BCE) (**Great Pyramid of Giza**)
- 1st Intermediate Period (2181–2055 BCE)
- Middle Kingdom (2055–1650 BCE), **Reisner Papyri** and **Moscow Papyrus**
- 2nd Intermediate Period (1650–1550 BCE), **Rhind Papyrus**
- New Kingdom (1550–1069 BCE)
- 3rd Intermediate Period (1069–664 BCE)
- Late Period (664–332 BCE)

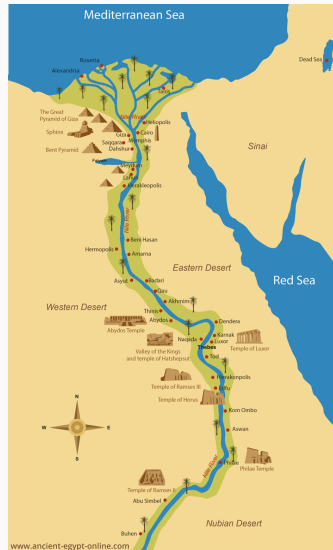

# The Papyri

- Papyri - scrolls.
  - Rhind Papyrus, 1650 BCE.
  - Moscow Papyrus, 1850 BCE.
  - Reisner Papyrus, 1950 BCE.
- Reisner Papyrus
  - Dr. G.A. Reisner .
  - 1901–04 - southern Egypt.
  - 4 scrolls.
  - Mostly accounts.
- Egyptian Arithmetic.
  - Base-10.
  - hieroglyphic and hieratic numerals.
  - integers, fractions.
  - surveying, building.
  - areas, volumes.

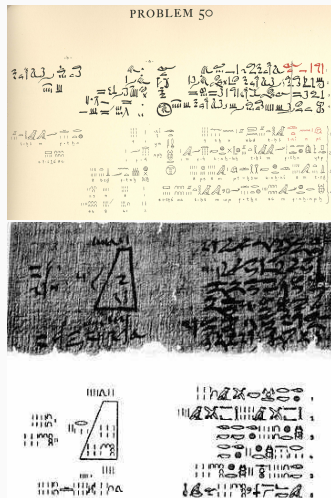
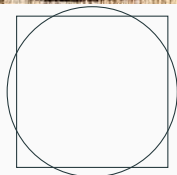
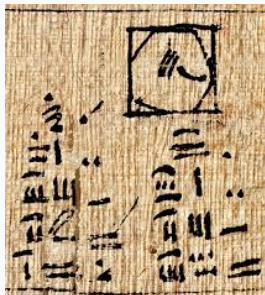

Figure 2: Papyri

# The Rhind Papyrus

- Found in Thebes.
- Purchased 1858, by A. Henry Rhind.
- Size: 18'  $\times$  13''.
- Red and black ink.
- Geometry.
  - Areas, Volumes.
  - Ratios of sides of right triangles.
- Measures - grain.
  - 1 hekat  $\approx 29,224 \text{ in}^3 \geq \frac{1}{2}$  peck.
  - 1 ro =  $\frac{1}{320}$  hekat.
- Areas of Circles - 48, 50.

$$A = \left(\frac{8}{9}D\right)^2 = \frac{256}{81}r^2 \approx 3.16049r^2.$$



$$A_{\text{circle}} = A_{\text{square}} - \frac{1}{9}A_{\text{square}}$$

**Figure 3:** Problem 48

# Pythagorean Triples

- Pythagorean Theorem.
- Triples  $(a, b, c)$ ,

$$a^2 + b^2 = c^2.$$

Examples:

- 3-4-5.
- 5-12-13.
- Used to Measure Perimeters.
- Knotted Ropes.
  - Loop with 12 knots.
- Other Units:
  - Finger - 1.9 cm.
  - Palm = 4 fingers - 7.5 cm.
  - Cubit = 7 palms - 52.3 cm.

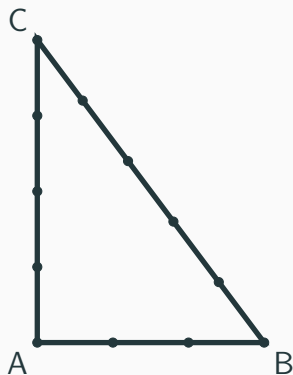





# Rhind Papyrus - Problem 50

## Problem 50

tp n ir-t ḥt dbn n ḥt-w<sup>1</sup> 9 pty rḥt · f m ḥt  
*Example of making a field round of khet 9. What is the amount of it in area?*

ḥb · ḥr · k ḡ · f m 1 ḏt m 8 ir-ḥr · k wḥ-tp m 8 sp 8 ḥpr · ḥr · f m 64  
*Take away thou 1/6 of it, namely, 1; the remainder is : 8. Make thou the multiplication : 8 times 8; becomes it : 64;*

rḥt · f pw m ḥt 60<sup>2</sup> ṣt<sup>3</sup> · t 4  
*the amount of it, this is, in area, 60 setat 4.*

ir-t my ḥpr  
*The doing as it occurs:*

1 9  
 ḡ · f 1.  
*of it*

ḥ[b] ḥnt · f ḏt 8  
*Take away from it; the remainder is 8.*

1	8
2	16
4	32
\ 8	64

rḥt · f m ḥt 60<sup>2</sup> ṣt<sup>3</sup> · t 4  
*The amount of it in area: 60 setat 4.*

<sup>1</sup> The w suggested by the plural strokes has been omitted on the plate. The same omission occurs on the figure in Problem 51, and in Problem 52, line 2.

<sup>2</sup> The scribe has by mistake written here either the number 60 or the special form for 6 used in Problem 48 in writing 6 *setat*. He may have had in his mind the fact that he was actually dealing with 60 *setat* (which, however, would not properly be written in this way), and he had written the abstract number 60 a moment before at the end of the multiplication, or, remembering that 60 *setat* is written with the numeral 6, he did write 6, but used the special sign instead of the ordinary numeral.

# Moscow Papyrus

- From around 1850 BCE.
- Golenishchev bought in 1892 or 1893 in Thebes.
- Housed in Moscow.
- 25 Problems.
- [https://en.wikipedia.org/wiki/Moscow\\_Mathematical\\_Papyrus](https://en.wikipedia.org/wiki/Moscow_Mathematical_Papyrus)
- See Problem 14:
  - Frustrum of a Pyramid

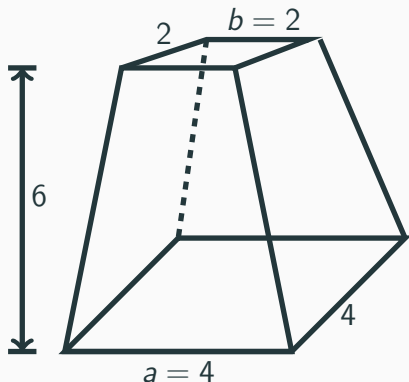

$$V = \frac{h}{3} (a^2 + ab + b^2)$$

# Moscow Papyrus - Problem 14 - Frustrum of Pyramid

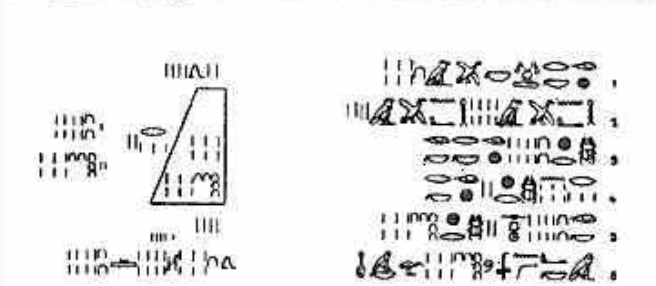



# Mesopotamia (2100 BCE) - Tigris and Euphrates Region

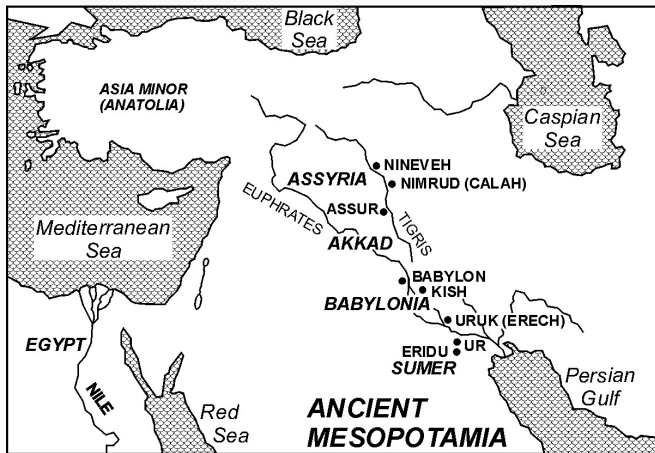

Figure 4: Tigris and Euphrates Rivers

# Babylonian and Sumerian Mathematics

- More Advanced.
- Clay Tablets.
- Base 60 Arithmetic.
- Notation:  $13_{60} = 1.3 = 1/3$ .
- Some use commas: 1,3.
- Examples:

$$1/3 = 1(60) + 3 = 63$$

$$1/59 = 1(60) + 59 = 119$$

$$2/49 = 2(60) + 49 = 169$$

$$3/31/49 = 3(60^2) + 31(60) + 49$$

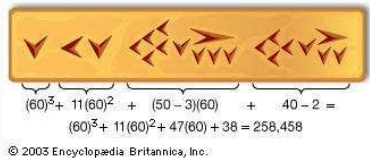

Figure 5: Babylonian tablet - Base 60

# Sexagesimal Operations (Base 60)

- Ambiguities:
  - No 0's.
  - No decimal points.
- Special fractions:
  - $8.25_{10} = 8/15 = 8\frac{15}{60}$
  - $8.5_{10} = 8/30 = 8\frac{30}{60}$
  - $8.75_{10} = 8/45 = 8\frac{45}{60}$
- Addition, subtraction, multiplication.

Addition:

$$\begin{array}{r} 14/28/31 \\ +3/35/45 \\ \hline = 18/4/16. \end{array}$$

Multiplication -

$$ab = \frac{1}{4} [(a + b)^2 - (a - b)^2].$$

No division! - Use reciprocals:

See [Old Babylonian Multiplication and Reciprocal Tables](#).

# Reciprocal Table

Table of reciprocals  $\bar{x}$  of  $x$ , where  $x\bar{x} = 60^n$ ,  $n = 0, 1, \dots$

$x$	$\bar{x}$	$x$	$\bar{x}$	$x$	$\bar{x}$	$x$	$\bar{x}$
2	0/30	8	7/30	16	3/45	30	2
3	0/20	9	6/40	18	3/20	32	1/52/30
4	0/15	10	6	20	3	36	1/40
5	0/12	12	5	24	2/30	40	1/30
6	0/10	15	4	25	2/24	45	1/20

Divide 8 by 2 :  $8(0/30) = 8 \times \frac{30}{60} = \frac{240}{60} = 4$ , or

$0/30 + 0/30 + 0/30 + 0/30 + 0/30 + 0/30 + 0/30 + 0/30 = 1 + 1 + 1 + 1$ .

Missing reciprocals:  $\frac{1}{7}, \frac{1}{11}, \frac{1}{13}, \frac{1}{17}, \frac{1}{19}, \dots$

# Sumerian Tablet - YBC 7289 - imšukkuḡ, or “hand tablet”

- From southern Iraq, 19th or 18th century BCE.
- Yale Peabody Museum of Natural History, 3D Print.
- Babylonians knew ratio of the side to diagonal in a square,  $1 : \sqrt{2}$ .



$$1/24/51/10 = 1 + \frac{24}{60} + \frac{51}{60^2} + \frac{10}{60^3} \approx 1.414213$$

$$42/25/35 = 42 + \frac{25}{60} + \frac{35}{60^2} \approx 42.426$$

# Plimpton 322 Clay Tablet (in the news in 2017)

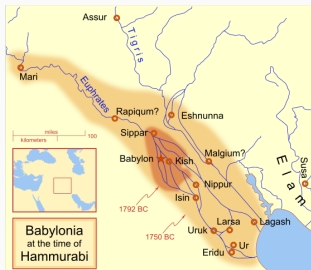

- Larsa (c. 1800 BCE) .
- Removed in 1920s.
- George Plimpton bought it, 1922.
- Left to Columbia University, 1936.
- It's about 13 by 9 by 2 cm.  
(Like a baking dish.)

- Four columns, cuneiform numbers.
- 15 rows - Pythagorean triples.
- 2nd column, side of right triangle.
- 3rd column, hypotenuse.
- 4th column, row number.
- What is the 1st Column?

# Plimpton 322 Clay Tablet - Homework!



# Sketch of the Plimpton 322 Tablet

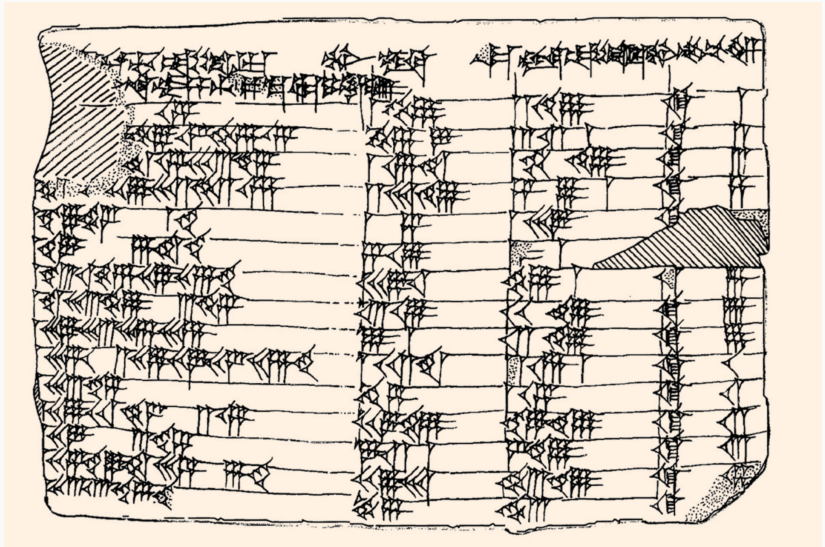

# Babylonian Numerals 1-100 (Base 60)

1	┌	26	𐍪	51	𐍪┌	76	┌ 𐍪
2	┌┌	27	𐍪┌	52	𐍪┌┌	77	┌ 𐍪┌
3	┌┌┌	28	𐍪┌┌	53	𐍪┌┌┌	78	┌ 𐍪┌┌
4	┌┌┌┌	29	𐍪┌┌┌	54	𐍪┌┌┌┌	79	┌ 𐍪┌┌┌
5	┌┌┌┌┌	30	𐍪	55	𐍪┌	80	┌ 𐍪
6	┌┌┌┌┌┌	31	𐍪┌	56	𐍪┌┌	81	┌ 𐍪┌
7	┌┌┌┌┌┌┌	32	𐍪┌┌	57	𐍪┌┌┌	82	┌ 𐍪┌┌
8	┌┌┌┌┌┌┌┌	33	𐍪┌┌┌	58	𐍪┌┌┌┌	83	┌ 𐍪┌┌┌
9	┌┌┌┌┌┌┌┌┌	34	𐍪┌┌┌┌	59	𐍪┌┌	84	┌ 𐍪┌┌
10	┌	35	𐍪┌┌	60	┌	85	┌ 𐍪┌
11	┌┌	36	𐍪┌┌┌	61	┌┌	86	┌ 𐍪┌┌
12	┌┌┌	37	𐍪┌┌┌┌	62	┌┌┌	87	┌ 𐍪┌┌┌
13	┌┌┌┌	38	𐍪┌┌┌┌┌	63	┌┌┌┌	88	┌ 𐍪┌┌┌┌
14	┌┌┌┌┌	39	𐍪┌┌┌┌┌┌	64	┌┌┌┌┌	89	┌ 𐍪┌┌┌┌┌
15	┌┌┌┌┌┌	40	𐍪	65	┌┌	90	┌ 𐍪
16	┌┌┌┌┌┌┌	41	𐍪┌	66	┌┌┌	91	┌ 𐍪┌
17	┌┌┌┌┌┌┌┌	42	𐍪┌┌	67	┌┌┌┌	92	┌ 𐍪┌┌
18	┌┌┌┌┌┌┌┌┌	43	𐍪┌┌┌	68	┌┌┌┌┌	93	┌ 𐍪┌┌┌
19	┌┌┌┌┌┌┌┌┌┌	44	𐍪┌┌┌┌	69	┌┌┌	94	┌ 𐍪┌┌
20	𐍪	45	𐍪┌	70	┌┌	95	┌ 𐍪┌
21	𐍪┌	46	𐍪┌┌	71	┌┌┌	96	┌ 𐍪┌┌
22	𐍪┌┌	47	𐍪┌┌┌	72	┌┌┌┌	97	┌ 𐍪┌┌┌
23	𐍪┌┌┌	48	𐍪┌┌┌┌	73	┌┌┌┌┌	98	┌ 𐍪┌┌┌┌
24	𐍪┌┌┌┌	49	𐍪┌┌	74	┌┌┌	99	┌ 𐍪┌┌
25	𐍪┌┌	50	𐍪	75	┌┌┌	100	┌ 𐍪

# Akkadian Table of 9's

## 2 Akkadian Tablet (-1700)

In the paper "Sherlock Holmes in Babylon," *Amer. Math. Monthly* 87 (1980), 335-345, C. Buck describes Babylonian mathematics. He begins with a discussion of a clay tablet from 3700 years ago as shown in Table 2. There are four columns. You should convince yourself that this is a table of 9's.

𐎶	𐎶𐎵	𐎶𐎵	𐎶 𐎶𐎵
𐎶𐎶	𐎶𐎶𐎵	𐎶𐎶	𐎶𐎶 𐎶𐎵
𐎶𐎶𐎶	𐎶𐎶𐎶𐎵	𐎶𐎶𐎶	𐎶𐎶𐎶 𐎶𐎵
𐎶𐎶𐎶𐎶	𐎶𐎶𐎶𐎶𐎵	𐎶𐎶𐎶𐎶	𐎶𐎶𐎶𐎶 𐎶𐎵
𐎶𐎶𐎶𐎶𐎶	𐎶𐎶𐎶𐎶𐎶𐎵	𐎶𐎶𐎶𐎶𐎶	𐎶𐎶𐎶𐎶𐎶 𐎶𐎵
𐎶𐎶𐎶𐎶𐎶𐎶	𐎶𐎶𐎶𐎶𐎶𐎶𐎵	𐎶𐎶𐎶𐎶𐎶𐎶	𐎶𐎶𐎶𐎶𐎶𐎶 𐎶𐎵
𐎶𐎶𐎶𐎶𐎶𐎶𐎶	𐎶𐎶𐎶𐎶𐎶𐎶𐎶𐎵	𐎶𐎶𐎶𐎶𐎶𐎶𐎶	𐎶𐎶𐎶𐎶𐎶𐎶𐎶 𐎶𐎵
𐎶𐎶𐎶𐎶𐎶𐎶𐎶𐎶	𐎶𐎶𐎶𐎶𐎶𐎶𐎶𐎶𐎵	𐎶𐎶𐎶𐎶𐎶𐎶𐎶𐎶	𐎶𐎶𐎶𐎶𐎶𐎶𐎶𐎶 𐎶𐎵
𐎶𐎶𐎶𐎶𐎶𐎶𐎶𐎶𐎶	𐎶𐎶𐎶𐎶𐎶𐎶𐎶𐎶𐎶𐎵	𐎶𐎶𐎶𐎶𐎶𐎶𐎶𐎶𐎶	𐎶𐎶𐎶𐎶𐎶𐎶𐎶𐎶𐎶 𐎶𐎵
𐎶𐎶𐎶𐎶𐎶𐎶𐎶𐎶𐎶𐎶	𐎶𐎶𐎶𐎶𐎶𐎶𐎶𐎶𐎶𐎶𐎵	𐎶𐎶𐎶𐎶𐎶𐎶𐎶𐎶𐎶𐎶	𐎶𐎶𐎶𐎶𐎶𐎶𐎶𐎶𐎶𐎶 𐎶𐎵
𐎶𐎶𐎶𐎶𐎶𐎶𐎶𐎶𐎶𐎶𐎶	𐎶𐎶𐎶𐎶𐎶𐎶𐎶𐎶𐎶𐎶𐎶𐎵	𐎶𐎶𐎶𐎶𐎶𐎶𐎶𐎶𐎶𐎶𐎶	𐎶𐎶𐎶𐎶𐎶𐎶𐎶𐎶𐎶𐎶𐎶 𐎶𐎵
𐎶𐎶𐎶𐎶𐎶𐎶𐎶𐎶𐎶𐎶𐎶𐎶	𐎶𐎶𐎶𐎶𐎶𐎶𐎶𐎶𐎶𐎶𐎶𐎶𐎵	𐎶𐎶𐎶𐎶𐎶𐎶𐎶𐎶𐎶𐎶𐎶𐎶	𐎶𐎶𐎶𐎶𐎶𐎶𐎶𐎶𐎶𐎶𐎶𐎶 𐎶𐎵

Table 2: Table of 9's.

As an example, the last entry in the first column is  $12 = \text{𐎶𐎵}$ . Then,  $9 \times 12 = 108 = \text{𐎶 𐎶𐎵}$ . Note that in base 60 we have  $108 = 1(60) + 48$ .

In the second column is a one ( 𐎶 ) and 48 ( 𐎶𐎵 ) separated by a space. Buck introduces a slash notation to write this as 1/48.

It is easy to add in base 60. Buck gives the example  $14/28/31 + 3/35/45 = 18/4/16$ .

# Babylonian Squares

How can a table of squares be useful? In modern notation, we see that

$$ab = \frac{1}{4} [(a+b)^2 - (a-b)^2]. \quad (1)$$

Let's find the product  $11 \times 14$ . Using Table 3, the formula gives

$$\begin{aligned} 11(14) &= \frac{1}{4} [(11+14)^2 - (11-14)^2] \\ &= \frac{1}{4} (25^2 - 3^2) \\ &= \frac{1}{4} (10/25 - 9) \text{ (base 60)} \\ &= \frac{1}{4} (10/16) \text{ (base 60)} \\ &= \frac{1}{4} (10(60) + 16) = \frac{616}{4} = 154. \end{aligned} \quad (2)$$

𐎠	𐎠 𐎠	𐎠𐎠	𐎠 𐎠	10	1/40	19	6/1
𐎠𐎠	𐎠 𐎠	𐎠𐎠	𐎠 𐎠 𐎠	11	2/1	20	6/40
𐎠𐎠𐎠	𐎠 𐎠𐎠	𐎠𐎠	𐎠𐎠 𐎠	12	2/24	21	7/21
𐎠𐎠𐎠𐎠	𐎠 𐎠𐎠𐎠	𐎠𐎠𐎠	𐎠𐎠 𐎠𐎠	13	2/49	22	8/4
𐎠𐎠𐎠𐎠𐎠	𐎠 𐎠𐎠𐎠	𐎠𐎠𐎠	𐎠𐎠 𐎠𐎠𐎠	14	3/16	23	8/49
𐎠𐎠𐎠𐎠𐎠𐎠	𐎠 𐎠𐎠𐎠	𐎠𐎠𐎠	𐎠𐎠 𐎠𐎠𐎠	15	3/45	24	9/36
𐎠𐎠𐎠𐎠𐎠𐎠𐎠	𐎠 𐎠𐎠𐎠	𐎠𐎠𐎠	𐎠 𐎠𐎠𐎠	16	4/16	25	10/25
𐎠𐎠𐎠𐎠𐎠𐎠𐎠𐎠	𐎠 𐎠𐎠𐎠	𐎠𐎠𐎠	𐎠𐎠 𐎠𐎠𐎠	17	4/49	26	11/16
𐎠𐎠𐎠𐎠𐎠𐎠𐎠𐎠𐎠	𐎠 𐎠𐎠𐎠	𐎠𐎠𐎠	𐎠𐎠 𐎠𐎠𐎠	18	5/24	27	12/9

Table 3: Table of squares with Babylonian numerals in the left table and slash notation on the right side.

## 4 Pythagorean Triples

Another interesting tablet from the time is the Plimpton 322 tablet shown in Figure 4. This tablet has a listing of Pythagorean triples. The last column has a list of numbers from 1 to 15. Columns two and three seem to be the hypotenuse,  $C$ , and one leg,  $B$ , of the right triangle shown in Figure 1. Recall from the Pythagorean Theorem that

$$C^2 = B^2 + D^2.$$

The triple  $(D, B, C)$  is called a Pythagorean triple.

We now know that these triples are parametrized by the pair  $(a, b)$  as follows:

$$B = a^2 - b^2, \quad C = a^2 + b^2, \quad D = 2ab,$$

since

$$(a^2 - b^2)^2 + (2ab)^2 = (a^2 + b^2)^2.$$

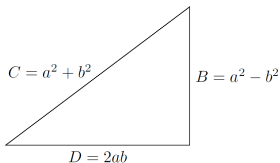

Figure 1: Right triangle with columns two and three as sides  $B$  and  $C$ , respectively. Pythagorean triples were later found to have a parametrization  $(a, b)$ .

# Transcription - Brackets indicate guesses

[59]/0/15	1/59	2/49	ki	1
[56/56]/58/14/50/6/15	56/7	1/20/25	ki	2
[55/7]/41/15/33/45	1/16/41	1/50/49	ki	3
53/10/29/32/52/16	3/31/49	5/9/1	ki	4
48/54/1/40	1/5	1/37	ki	[5]
47/6/41/40	5/19	8/1	[ki]	[6]
43/11/56/28/26/40	38/11	59/1	ki	7
41/33/45/14/3/45	13/19	20/49	ki	8
38/33/36/36	8/1	12/49	ki	9
35/10/2/28/27/24/26/40	1/22/41	2/16/1	ki	10
33/45	45	1/15	ki	11
29/21/54/2/15	27/59	48/49	ki	12
27/0/3/45	2/41	4/49	ki	13
25/48/51/35/6/40	29/31	53/49	ki	14
23/13/46/40	56	53	ki	[15]

# Sketch of the Plimpton 322 Tablet

il-ti si-li-ip -tim ib-sá		sag ib-sá si-li-ip-tim mu-bi-im	
na-as-sá-bu-ú-ma sag ti-ú			
15	159	249	ki 1
58145615	567	3121	ki 2
1153345	11641	1549	ki 3
5729325216	33149	591	ki 4
4854 14	15	137	ki 5
47 6414	519	81	
43115628264	3811	591	ki 7
413359 345	1319	249	ki 8
38333636	91	1249	ki 9
351 228 2724 264	12241	2161	ki 1
3345	45	115	ki 11
292154 215	2759	4849	ki 12
27 345	7121	449	ki 13
25485135 64	2931	5349	ki 14
2313 764	56	53	ki

Figure 6: Arabic numerals base 60. The bars designate place holders.

# Buck's Corrected Values

Second column - base 60 values for  $(B/D)^2$  with  $D^2 = C^2 - B^2$ .

#	A	B	C	a	b
1	59/0/15	119	169	12	5
2	56/56/58/14/50/6/15	3367	4825	64	27
3	55/7/41/15/33/45	4601	6649	75	32
4	53/10/29/32/52/16	12709	18541	125	54
5	48/54/1/40	65	97	9	4
6	47/6/41/40	319	481	20	9
7	43/11/56/28/26/40	2291	3541	54	25
8	41/33/45/14/3/45	799	1249	32	15
9	38/33/36/36	481	769	25	12
10	35/10/2/28/27/24/26/40	4961	8161	81	40
11	33/45	45	75	1	0.5
12	29/21/54/2/15	1679	2929	48	25
13	27/0/3/45	161	289	15	8
14	25/48/51/35/6/40	1771	3229	50	27
15	23/13/46/40	56	106	9	5

# First Column Computation

- Buck suggests column A is  $\left(\frac{B}{D}\right)^2$ .
- Others suggest  $\left(\frac{C}{D}\right)^2$  and missing left part of the stone had 1's.

Noting,

$$\left(\frac{C}{D}\right)^2 = 1 + \left(\frac{B}{D}\right)^2.$$

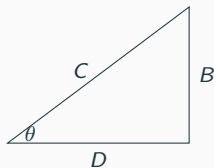

From row 1: 59/0/15 represents

$$\frac{59}{60} + \frac{0}{60^2} + \frac{15}{60^3} = \frac{14161}{14400}.$$

From row 1:  $B = 119$ ,  $C = 169$  :

$$\begin{aligned} B^2 &= 119^2 = 14161 \\ D^2 &= 169^2 - 119^2 = 14400 \\ \left(\frac{B}{D}\right)^2 &= \frac{14161}{14400}. \end{aligned}$$

# Decimal Equivalents for Column One

#	A	Decimal Value	$(B/D)^2$
1	59/0/15	0.9834027777777778	0.9834027777777778
2	56/56/58/14/50/6/15	0.949158552088692	0.949158552088692
3	55/7/41/15/33/45	0.918802126736111	0.918802126736111
4	53/10/29/32/52/16	0.886247906721536	0.886247906721536
5	48/54/1/40	0.815007716049383	0.815007716049383
6	47/6/41/40	0.785192901234568	0.785192901234568
7	43/11/56/28/26/40	0.719983676268862	0.719983676268862
8	41/33/45/14/3/45	0.692709418402778	0.692709418402778
9	38/33/36/36	0.6426694444444444	0.6426694444444444
10	35/10/2/28/27/24/26/40	0.586122566110349	0.586122566110349
11	33/45	0.5625000000000000	0.5625000000000000
12	29/21/54/2/15	0.489416840277778	0.489416840277778
13	27/0/3/45	0.4500173611111111	0.4500173611111111
14	25/48/51/35/6/40	0.430238820301783	0.430238820301783
15	23/13/46/40	0.387160493827161	0.387160493827161



- 1900-1600 BC.
- Field plan.
- Used Pythagorean triples to make accurate right angles for measuring boundaries.
- Proposes that Plimpton 322 is the world's oldest and most accurate trigonometric table. (8/2017) [Youtube](#)
- [Robson](#) does not view it that way.



D.F. Mansfield. Plimpton 322: A Study of Rectangles. Found Sci, published online August 3, 2021; [Paper](#).

# Babylonian Geometry

- Simple shapes.
- Interested in areas.
- Fields, subdivisions.
- Inclinations, slopes.
- seked, ukuklu, run/rise.

See N. Wildberger's [YouTube](#) and reference Neugebauer and Sachs, ed., 1945, *Mathematical Cuneiform Texts*.

Neugebauer and Sachs Introduced Plimpton 322.

Wildberger and Mansfield - Babylonian trigonometry based on ratios.

