

PHYSICS 202 LAB 4: EFFECTIVE RESISTANCE OF SERIES AND PARALLEL
CIRCUITS
DR. TIMOTHY C. BLACK
SPRING, 2009

THEORETICAL DISCUSSION

The Junction Rule: Since charge is conserved, it is neither created nor destroyed at any point in the circuit. In particular, at a junction (a point where lines or elements connect together), the total amount of charge entering the junction is the same as the amount leaving the junction. This leads to the so-called *Junction Rule*:

The sum of the currents entering any junction must equal the sum of the currents leaving that junction.

Mathematically, this means that the algebraic sum of the currents at a junction is zero.

$$\sum_{\text{junction}} I_j = 0$$

The Loop Rule: The Loop rule is a consequence of energy conservation. For conservative forces, the change in potential energy U in traversing any closed path is zero. Since the electric potential V is the electric potential energy per unit charge, and the electric force is conservative, it follows that the change in potential in traversing any closed circuit loop is also zero. This leads to the so-called *Loop Rule*.

The algebraic sum of the changes in electric potential encountered in a complete traversal of any closed loop of a circuit is zero.

A mathematical statement of this rule is

$$\sum_{\text{loop}} V_j = 0$$

Circuit Elements in Parallel and in Series: Consider figures 1 and 2. Circuit elements configured as in figure 1 are said to be connected *in series*. This means that all electrons



Fig. 1: Series connection

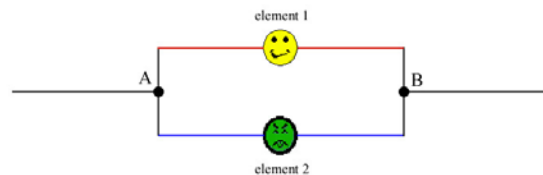

Fig. 2: Parallel connection

in the current flow must pass through both element 1 and element 2 as they go from point A to point B in the circuit. Circuit elements configured as in figure 2 are said to be

connected *in parallel*. This means that any given electron in the flow of current may traverse either element 1 or element 2 in going from point A to point B, but not both.

Effective Resistance of a Circuit: Any combination of resistors in a circuit, whether in series or in parallel, can always be considered as equivalent to some *effective resistance* in the following sense: If V_{tot} is the total potential drop across the circuit, and I_{tot} is the total current through the circuit, then the effective resistance is defined by

$$R_{eff} = \frac{V_{tot}}{I_{tot}} \quad \text{Eqn. 1}$$

Effective Resistance of Parallel Circuits: Consider the circuit diagram of figure 3. Kirkhoff's loop rule implies that the total change in voltage in traversing the loop from point A to point B and back to A again is zero. Furthermore, the voltage drop from A to B is independent of the path, so that

$$V_{tot} = V_{AB} = V_{path 1} = V_{path 2}$$

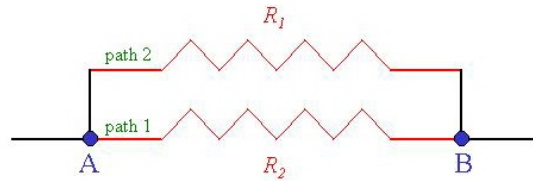

Fig. 3: Resistors connected in parallel

Since resistors are ohmic devices and obey Ohm's Law for all V and I , it follows that

$$I_1 = \frac{V_{AB}}{R_1} \qquad I_2 = \frac{V_{AB}}{R_2}$$

where I_1 and I_2 are the currents through paths 1 and 2, respectively. According to its definition, the effective resistance R_{eff} for the parallel configuration of resistors 1 and 2 is given by

$$R_{eff} = \frac{V_{AB}}{I_{tot}} \quad \text{Eqn. 2}$$

where the junction rule implies that the total current I_{tot} is given by

$$I_{tot} = I_1 + I_2 = \frac{V_{AB}}{R_1} + \frac{V_{AB}}{R_2} = V_{AB} \left(\frac{1}{R_1} + \frac{1}{R_2} \right)$$

Combining this result with equation 2 gives

$$R_{eff} = \frac{1}{\left(\frac{1}{R_1} + \frac{1}{R_2} \right)} \quad \text{Eqn. 3}$$

This result is easily generalized. For N resistors in parallel,

$$R_{eff} = \frac{1}{\sum_{j=1}^N \frac{1}{R_j}}$$

Effective Resistance of Series Circuits: Consider now the circuit diagram shown in figure 4. According to the loop rule, the total potential drop from point A to point C is equal to the sum of the potential drop from A to B and the potential drop from B to C, so that

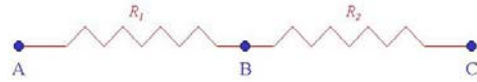

Fig. 4: Resistors connected in series

$$V_{tot} = V_{AC} = V_{AB} + V_{BC}$$

Since the same current flows from A to B, and from B to C, and thus from A to C, the total current is equal to the currents through either of the resistors:

$$I_{tot} = I_1 = I_2$$

Then according to the definition of effective resistance,

$$R_{eff} = \frac{V_{tot}}{I_{tot}} = \frac{V_{AB}}{I_1} + \frac{V_{BC}}{I_2},$$

so that

$$R_{eff} = R_1 + R_2 \quad \text{Eqn. 4}$$

This result can also be generalized to any number of resistors. For N resistors in series,

$$R_{eff} = \sum_{j=1}^N R_j$$

EXPERIMENTAL PROCEDURE

1. Use an ohmmeter to measure the resistance of resistors R_1 and R_2 .
2. Connect the parallel resistance circuit shown in figure 5.
 - a. Calculate the effective resistance $R_{||}^{(calc)}$ of this circuit using the measured values of R_1 and R_2 and equation 3.

- b. Adjust the power supply to give a voltage drop of $V_{AB} \approx 10 \text{ V}$ across points A and B . Use the voltmeter to measure V_{AB} and record this value.
- c. Use the ammeter to measure the total current I_{tot} through the circuit and record this value.

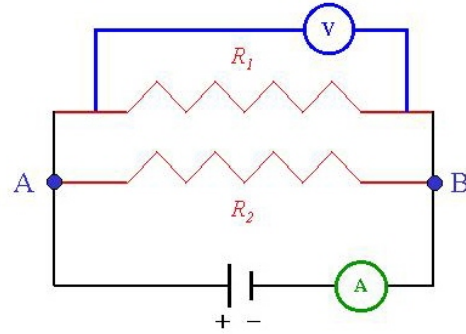

Fig. 5: Experimental parallel circuit

- d. Use your measurements of V_{AB} , I_{tot} , and equation 1 to calculate the experimental value of the effective resistance, $R_{||}^{(exp)}$.
- e. Numerically compare $R_{||}^{(calc)}$ with $R_{||}^{(exp)}$ by calculating their fractional discrepancy.

3. Connect the series resistance circuit shown in figure 6.

- a. Calculate the effective resistance $R_{series}^{(calc)}$ of this circuit using the measured values of R_1 and R_2 and equation 4.

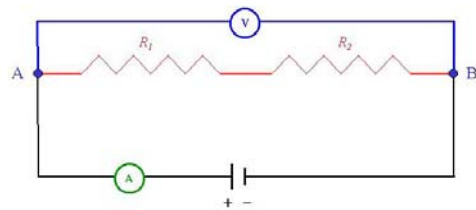

Fig. 6: Experimental series circuit

- b. Adjust the power supply to give a voltage drop of $V_{AB} \approx 10 \text{ V}$ across points A and B . Use the voltmeter to measure V_{AB} and record this value.
- c. Use the ammeter to measure the total current I_{tot} through the circuit and record this value.
- d. Use your measurements of V_{AB} , I_{tot} , and equation 1 to calculate the experimental value of the effective resistance, $R_{series}^{(exp)}$.
- e. Numerically compare $R_{series}^{(calc)}$ with $R_{series}^{(exp)}$ by calculating their fractional discrepancy.